

Overview

The V-Linx FDH is an indoor V-Linx connectivity interface with a maximum capacity of 144 OCU units.

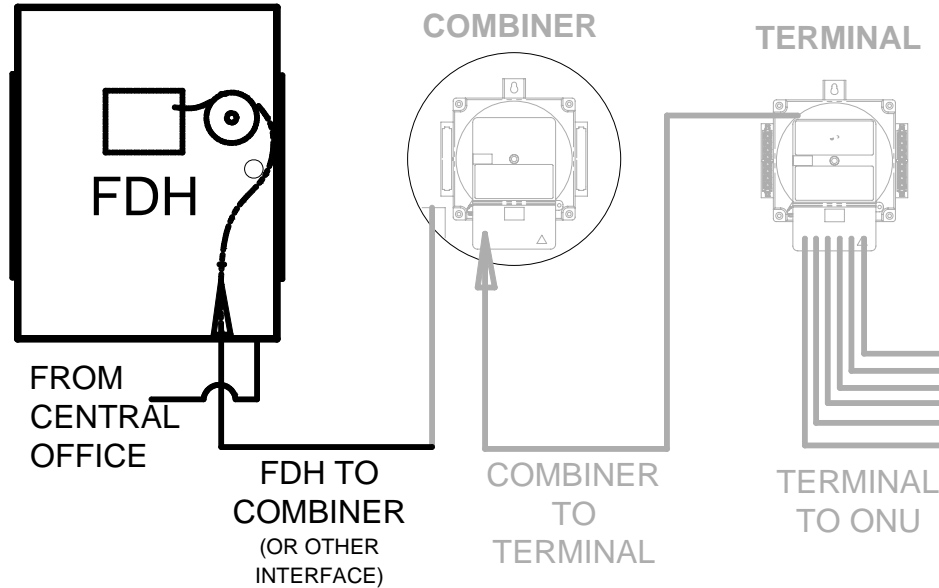

V-LINX SYSTEM DIAGRAM

FIGURE 1

The V-Linx FDH parts include:

- V-Linx FDH unit (1)
- Wall Mount Bracket (1)
- Bagged Parking Adapter (4)
- Installation Manual (1)
- Cable Grip (3) Split Tube (2)

Recommended tools and hardware:

- Measuring tape
- 12VDC or larger drill/ driver
- 7/16 wrench or socket driver
- Crescent Wrench
- 7/16 Can wrench tool
- Single fiber /ribbon splicing machine
- Ribbon fiber stripper tool
- Single fiber stripping tool
- Scissors
- Multi-fiber cable stripping tools

Note: Wall Mount Bracket hardware is not supplied. The installation contractor is to determine the appropriate 5/16 to 3/8 inch sized hardware for the wall mounting surface. The FDH fully loaded weight is approximately 75 pounds

Installation instructions:

1. - Determine the optimum location for the V-Linx FDH. The recommended mounting is to an interior wall approximately 48 inches from the floor to bottom of the Wall Mount Bracket.

Note: The four mount holes are spaced on 16 inch centers.

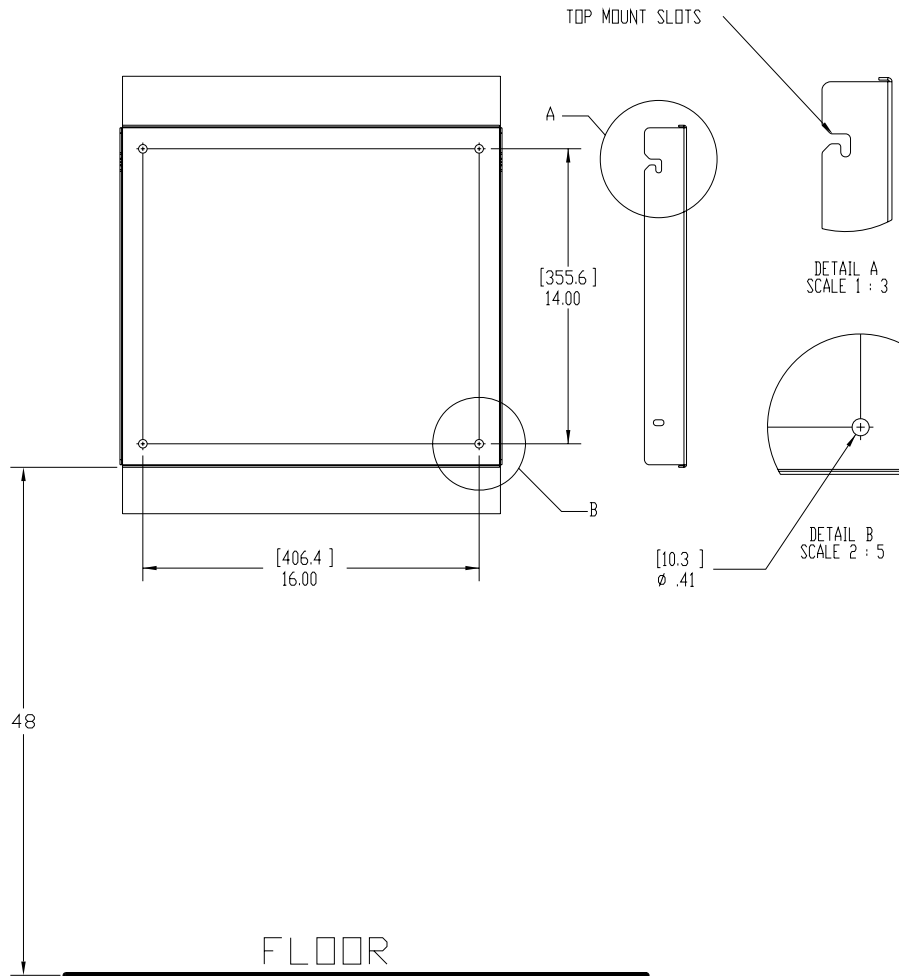

Fig. 2

Note 1: Wall Mount Bracket hardware is not supplied. The installation contractor is to determine the appropriate 5/16 to 3/8 inch sized hardware for the wall mounting surface. The FDH fully loaded weight is approximately 75 pounds

2. – Place the Wall Mount Bracket level to the wall surface and mark the inside of the four holes at the desired location.
3. – Install the bracket with the slot side up and to the wall with four contractor supplied bolts. (See note one)
4. – Temporarily remove the two lower ¼-20 x ½ inch long bolts from the enclosure.
5. – Temporarily back out the two top bolts approximately ¼ inch from the enclosure side walls.
6. – Lift the enclosure to the Wall Mount Bracket and hang the enclosure to the mating slotted openings.
7. – Reinstall the two bottom bolts and tighten all four bolts.

The FDH is now prepared for fiber optic cable, fiber splicing and splitter installation.

8. – Proceed to open the door latch with a 7/16 can wrench, fully open the door until the door keeper is engaged.

9. – Install the factory Direct Connect Splitter(s) into the upper left corner bracket of the swing panel. (Refer to Figure 3)

Note: The FDH splitter capacity is up to four splitters. The splitter installation label must face towards the bracket. The Direct Connect splitter is to be snapped into the mating alignment slots with the cable fanout facing downward.

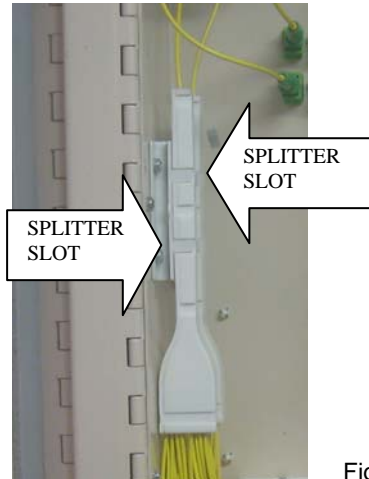

Figure 3

10. – Install each of the splitter single fiber cables into the F1- F4 upper left SC type adapters in sequential order to the corresponding Direct Connect splitter. (Refer to Figure 4)

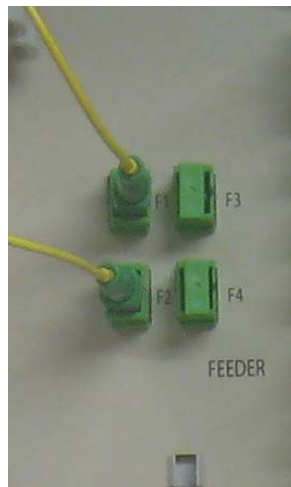

Figure 4

Note: Clean and inspect the Direct Connect SC connector ends prior to connection.

11. Carefully place the connectorized fanout cables into the swing panel bottom tray

The FDH swing panel front fiber portion of assembly is now prepared.

12. – Proceed to open the swing panel. Utilizing a flat screw driver unlatch the upper right hand corner latch by rotating 90 degrees in a clockwise direction, next pull the lower right latch up. The swing panel can now swing out and lock at 90 degrees.

13. – Install the entry cable through the larger bottom right cable strain relief location. Complete preparation of the entry cable to the cable manufacturer's recommendations.

Note: The recommended rough in length of fiber from the inside cable clamp to the end if the fiber is 60 inches.

14. – Insert the feeder fibers into 24 inch long 3mm buffer tubing and route around the top right take-up spool and into the top splice tray. (Refer to Figure 6)

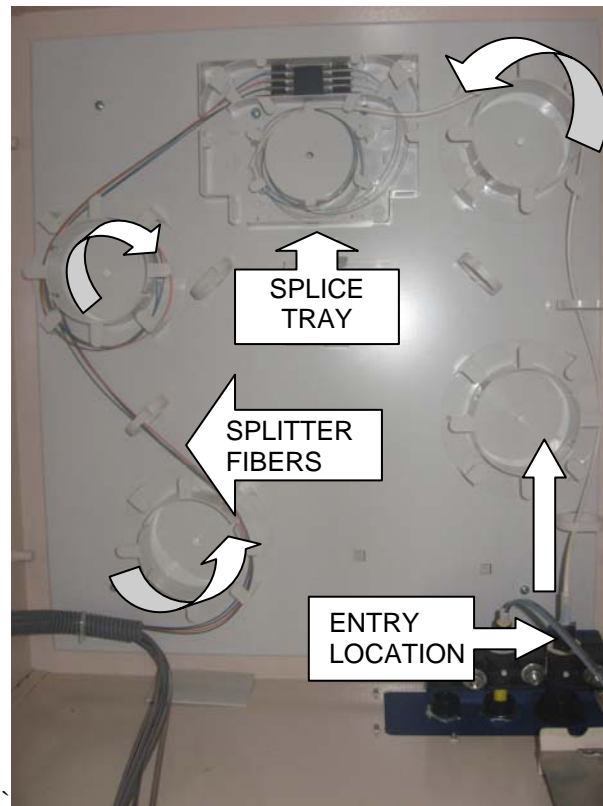

Figure 6

15. – Route the factory installed splitter fibers as recommended on the back panel diagram. The fibers should wrap around the take-up spool and into the top splice tray as shown in Figure 6.

Note: The recommended fiber length is 38 inches from the flexible conduit end to fiber bare end.

16. – Splice the fibers to industry methods and secure the spliced fibers to the splice tray. Install the small foam rubber retainer as shown in Figure 7.

16. – Splice the fibers to industry methods and secure the spliced fibers to the splice tray. Install the small foam rubber retainer as shown in Figure 7.

Note: To facilitate splicing the enclosure floor maybe used to rest the splicing tools

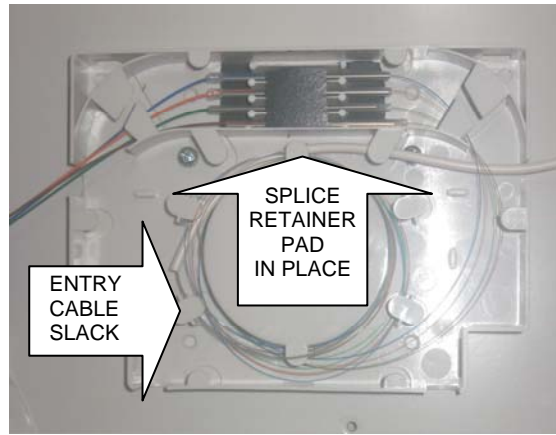

Figure 7

17. Replace the splice tray cover over the tray and adjust fiber slack as needed.

The FDH entry fiber portion of the installation is now complete

18. – Proceed to install the V-Linx Combiner cable (or other customer prescribed interface).

19. – Install the combiner cable through the smaller bottom cable strain relief locations. Install the clear split tube to adapt the combiner cable to the cable clamp. Complete preparation of the entry cable to recommended industry practices.

20. – Route the fiber ribbons around the lower take-up spools and to the ribbon splice tray as shown on the back panel diagram. (Refer to Figure 8)

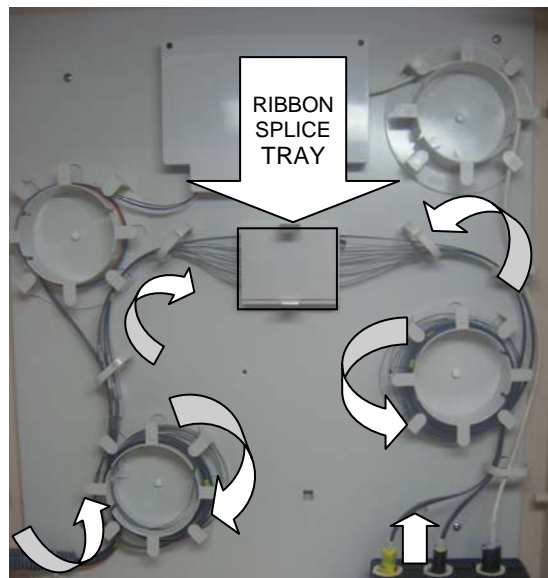

FIGURE 8
(Fiber routing to ribbon splice tray)

21. – Route the factory installed ribbon fiber (R1-R12) as recommended on the back panel diagram. The fibers should wrap around the take-up spool 2-4 times before entering the splice tray.

22. – Splice the fibers to recommended industry practices and secure the spliced fibers to the splice tray and back panel bracket.

Recommendation: Sequentially install ribbons R1-R5 into the first splice tray and R6-R10 into the second splice tray.

Note: To facilitate splicing the enclosure floor maybe used to rest the splicing tools.

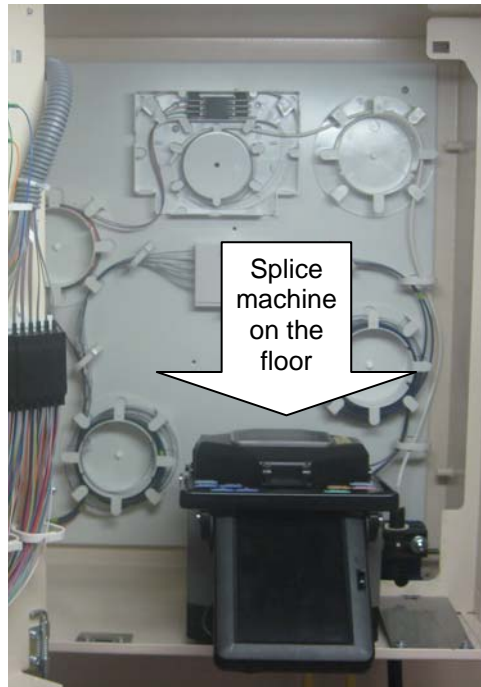

Figure 9

23. Adjust fiber slack as needed and replace the splice tray cover over the tray. Store any remaining unused ribbons coiled into the center of the bottom left take-up spool.

The FDH ONU fiber portion of the installation is now complete

24. – Complete any required system testing to common industry practices and tighten the cable clamps.

**The FDH unit is now ready for front panel customer connections
(Refer to Figure 10)**

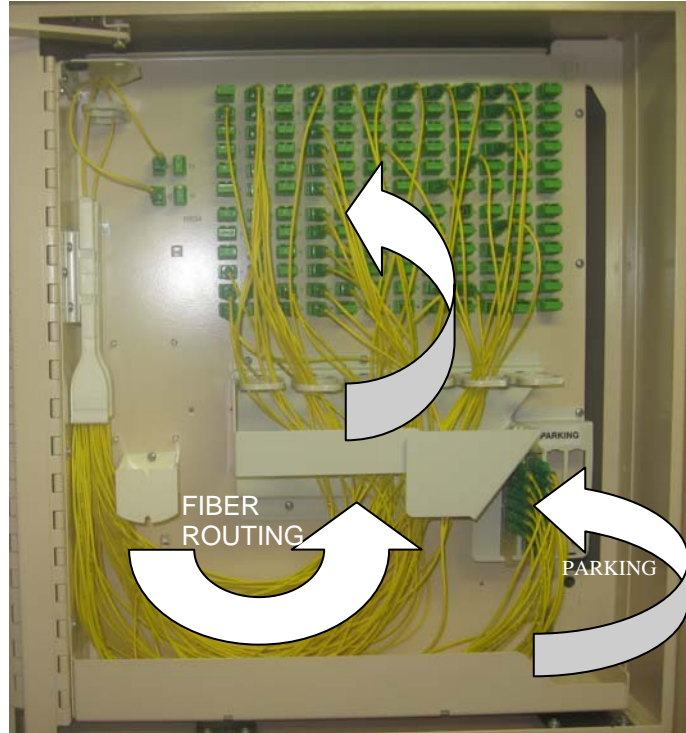

Figure 10
(Front Panel Connectivity Diagram)